



# AEROCELL SRW



The **Aerocell SRW** bridges the gap between cargo vans and cube vans. Designed exclusively for the tough, dependable, comfortable and stylish GM single rear wheel cutaway chassis, this new van body offers all of the same benefits as the original Aerocell: one piece molded fiberglass construction, seamless and glossy gel coat exterior, and aerodynamic styling. The completed vehicle has the extra height and capacity cargo vans lack, as well as the **aesthetics, driveability** and **convenience** missing from most cube vans. The standard package size of the competitively priced SRW makes ordering simple. The Aerocell SRW is an **ideal solution**.

- |                  |                 |
|------------------|-----------------|
| Cable            | Janitorial      |
| Carpenters       | Locksmiths      |
| Carpet Cleaners  | Mobile Repairs  |
| Caterers         | Municipalities  |
| Contractors      | Painters        |
| Delivery Service | Plumbers        |
| Electricians     | Retailers       |
| Food Service     | Rentals         |
| Furniture        | TV & Appliances |
| HVAC             | Utilities       |

## UNICELL

THE ONE PIECE FIBERGLASS VAN BODY

# AEROCELL SRW

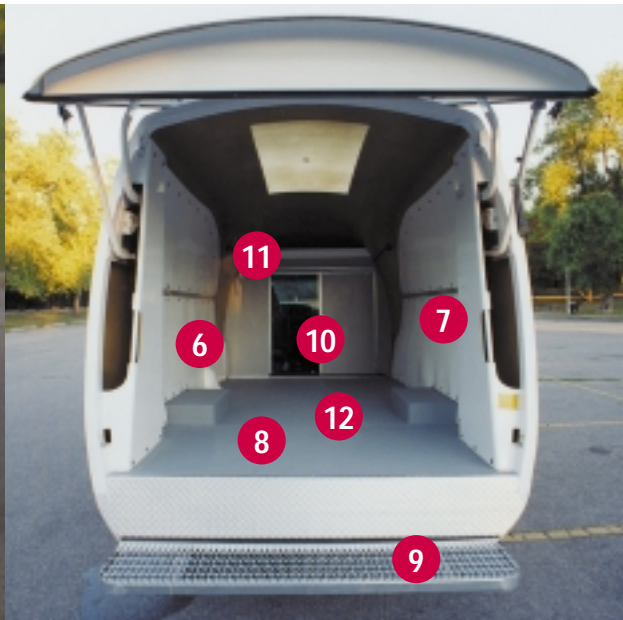
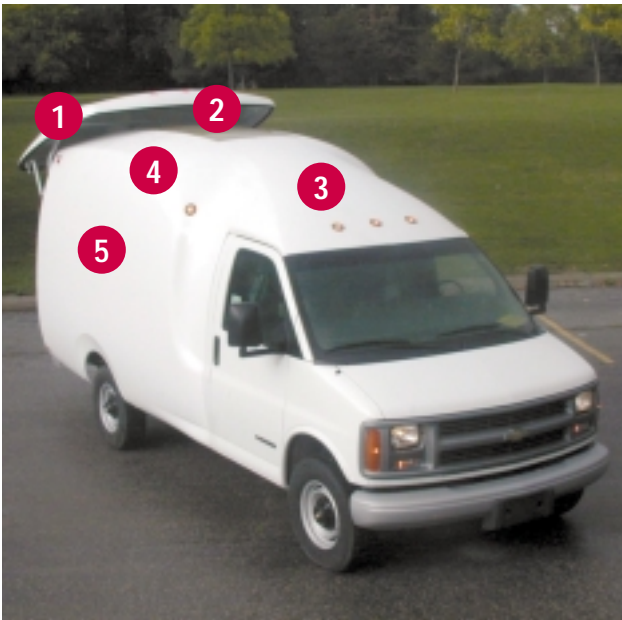

- 1 Unique easy-to-operate flip-up rear door with keyed lock and inside release handle has unrestricted load access and full height entry
- 2 Built-in translucent skylight for a brightly lit work interior
- 3 Integral roof fairing and flowing body contours offer fuel-saving aerodynamics and visual appeal
- 4 The one piece molded fiberglass outer skin has no seams, rivets, or caulk, so it won't leak
- 5 The smooth glossy surface enhances your company's image-boosting graphic message
- 6 High density polyethylene lining is strong and brightens interior workspace
- 7 Full length aluminum aircraft quality logistic track with adjustable tie rings and shelving attachment bolts
- 8 Tough tongue and groove plywood floor
- 9 Extra deep non-skid step bumper
- 10 Sliding access door to cab
- 11 Built-in shelf for added storage over cab
- 12 466 cubic feet of cargo space

## DIMENSIONS

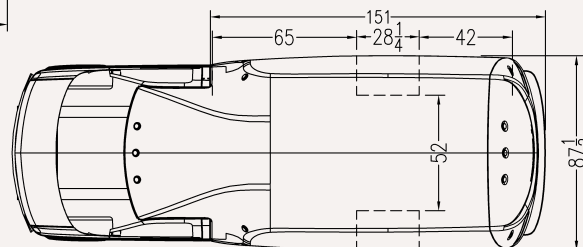
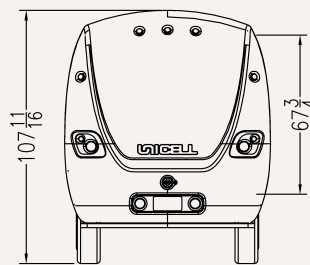
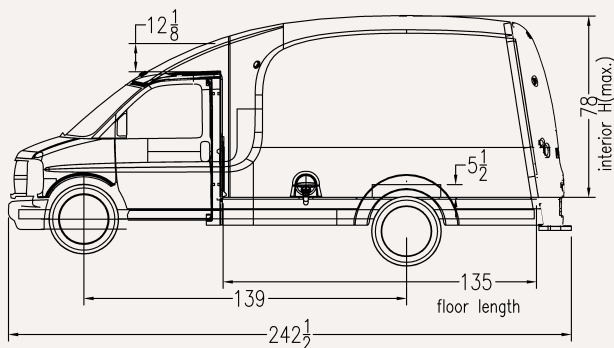

The Aerocell SRW is backed by a five year limited warranty and our 25 years of experience in building van bodies.

### UNICELL BODY COMPANY, INC.

571 Howard Street Buffalo, NY 14206  
 Toll Free 800/628.8914 • Local 716/853.8628  
 Fax 716/843.8638 • [www.unicell.com](http://www.unicell.com)

Due to continuous product improvements, specifications may change without notice. Chassis available through Unicell pool stock. Contact your local Chevrolet or GMC dealer for pricing.