



# SERVICELL VAN BODY



Two industry-leaders, whose names are synonymous with premium quality, have joined to produce the **finest service van available**. The **new Servicell** combines the visual appeal and long life construction of **Unicell Body Company's** one-piece fiberglass hi-cube body with the versatility and function of **Knapheide Truck's** rugged utility body.

A **roomy interior** offers stand up height with lots of well-lit cargo and workspace.

On the outside, practical and **secure storage compartments** for exterior access to tools and parts.

Available in 12' and 14' lengths and two body styles for **General Motor's** dual rear wheel cutaway van. Custom lengths and options are available to suit. The **Servicell** is built to **serve you well**.

- Plumbers
- Electricians
- Carpenters
- Contractors
- HVAC
- Home Service and Repair
- Appliance Installation and Service
- Mobile Repair
- Mobile Tire Service
- Garage Door Service
- Fence Installers
- Cable
- Painters
- Schools
- Landscaping
- Utilities

**UNICELL**®





1 Bright and roomy interior



2 Easy access inside and out



3 A place for everything



4 Store items big and small



5 50" swing out doors shown with optional ladder rack and removable rear step ladder

## STANDARD EQUIPMENT

### CONSTRUCTION

- Upper body: One-piece fiberglass upper with glossy white gel coat exterior
- Lower body: 14-gauge two-sided A-40 galvalneal steel with durable corrosion-resisting primer layer and acrylic enamel finish coat
- 20 ga. two-sided galvalneal steel lower body with an oven cured, electro-deposition gray primer

### DOORS

- 50" wide swing out rear doors
- Double shell, 20-gauge, reinforced side doors
- Inside access to horizontal side compartment
- Rubber door bumpers and chain retainers on horizontal side doors

### FLOOR

- 1-1/2" Dense yellow pine with tough urethane finish

### WALLS

- 3/8" Plywood from compartments to ceiling

### LIGHTING

- Translucent leak-proof skylight
- 12v Dome light
- DOT approved exterior lights

### BUMPER

- Galvanized grip-strut extra deep safety rear step bumper

### PROTECTION

- Weather-proof wiring system
- Full body corrosion-resisting undercoat

## OPTIONAL EQUIPMENT

### DOORS

- Roll-up rear door
- Various width single and double panel swing out rear doors
- Master locking system for side compartment doors

### CARGO CONTROL

- Roof mounted ladder rack system
- D-rings and E-track
- Shelving

### FLOORS

- Laminated hardwood
- HD Plastic
- Steel or aluminum tread plate overlay

### ACCESS

- Sliding access door between cab and body
- Vertical cabinet access from inside body
- Full height walk-through cab (Aerocell model)

### WINDOWS

- For rear doors or upper body sides

## DIMENSIONS

SIDE COMPARTMENT DIMENSIONS			
12' Body	Length	Height	Depth
A	20-1/4"	40"	22"
B	21"	40"	22"
C	52-3/4"	18-1/2"	22"
D	31-1/4"	40"	22"
14' body	Length	Height	Depth
E	30-1/4"	40"	22"
F	29"	40"	22"
G	52-3/4"	18-1/2"	22"
H	35-1/4"	40"	22"

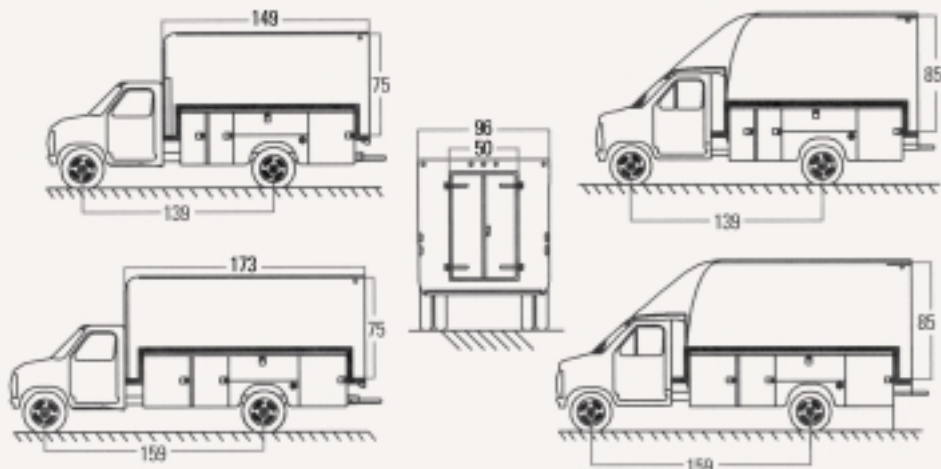

The Servicell is backed by a five-year warranty as well as over 100 years in truck body building experience.

**UNICELL BODY COMPANY, INC.**  
 571 Howard Street Buffalo, NY 14206  
 Toll Free 800/628.8914 • Local 716/853.8628  
[www.unicell.com](http://www.unicell.com)

Due to continuous product improvements, specifications may change without notice. Chassis available through Unicell pool stock. Contact your local Chevrolet or GMC dealer for pricing.